

Welcome to oms

欢迎来奥美森参观指导!

股票代码: 833340



奥美森 智能装备

OMS MACHINERY

每天更進一步
One More Step



扫一扫 关注我们

www.china-oms.com

奥美森智能装备股份有限公司
OMS MACHINERY CO.,LTD

地址: 广东省中山市南区大新路1号
 Add: 1-1Daxin Road, South District,Zhongshan City,Guangdong ,China
 总机(Tel): 0760-88885860 88388670
 传真(Fax): 0760-88885870
 销售热线(sales hot-line): 0760-89913289
 E-mail: sale@china-oms.com
 (国内) serv@china-oms.com
 xc2009@china-oms.com
 WL@china-oms.com
 (国外 overseas market)
 scld_mc@163.com
 售后热线(service hot-line): 400-788-1345
 E-mail: sh@china-oms.com
 邮编(Post): 528455



奥美森智能装备股份有限公司
OMS MACHINERY CO.,LTD



■ 办公综合楼 Office building

公司简介 Introduction

奥美森智能装备股份有限公司前身是“中山市奥美森工业有限公司”位于伟人故里中山市，是主要从事研发制造自动化、数字化、智能化装备的国家火炬计划重点高新技术企业、广东省知识产权示范企业、广东省名牌产品企业、标准化良好行为企业，设有广东省省级企业技术中心、广东省工程技术研究开发中心、广东省工程实验室。已通过ISO质量管理体系和测量管理体系认证。拥有专业研发人员80余人，加工设备齐备。与北京理工大学、华南理工大学、武汉理工大学等10余所高等院校开展产学研合作，为企业高新技术发展提供了技术支持。截止2015年6月，共申请专利364项，已获国家知识产权局授权的218项，其中发明专利61项。

公司产品主要包括配管加工类、空调换热器加工类、环保机械类、定制类、工业机器人、新能源综合利用等设备，是国内智能装备行业的领先企业、国内空调换热器生产专用设备的龙头企业。产品具有高精度、高效率、节能、节材等优点，并以优美的外观、卓越的性能、人性化的操作等特点赢得了海内外广大用户的青睐，用户遍布全球。

奥美森人秉承“锲而不舍、精益求精、开拓创新、与时俱进”的宗旨，以提高中国的工业装备水平、赶超世界为己任，努力践行着实业兴国的“中国梦”！

OMS Machinery Co., Ltd. is a High-Tech company, dedicated to the development and production of automatization, digitalization, and intelligentization equipment. Located in Zhongshan, Guangdong, OMS employs 80 professional engineers, and is well equipped with facilities. The company's quality system and measurement system are ISO certified. OMS maintains close cooperation with many universities, which backs the development of new technologies in business. The company has acquired over 100 patents, and is included in China Torch Program.

The company's business is comprised of the following: tube and heat exchanger processing machines, environmental equipment, custom machines, industrial robots, new energy equipment, etc. In China, OMS stands as the leading company in the intelligentization equipment industry, and the largest machinery supplier for air conditioning heat exchanger production. OMS products feature high precision, high efficiency, energy and resource saving, and have been highly rated for the exquisite design, outstanding performance, and user-friendliness by customers around the world.

OMS is a vigorous young group full of energy and new ideas, and will always be committed to improvement, innovation, and customer satisfaction.

资质荣誉 Qualification



奥美森智能装备

信誉是我们的原动力

Sound credibility is our driving force

公司在不断地发展提升，获得了众多的荣誉，这些荣誉代表了我们的过去，是对我们的一种认可，并激励我们不断进取，攀登新的高度。

Continuous development and improvement brings us many honors, which recognizes our past achievement. Now it is inspiring us to make constant improvement and climb new heights.



专利证书 (218余项) patent certificate (total: 218)
其中发明专利 (61项) 61 patents for invention



CE证书 CE certificate



质量管理证书 quality management certificate



机架及构件制造过程
Fabrication of machine frame and structures



数控等离子切割机 CNC plasma cutting machine



折板机 press brake



龙门综合加工中心 gantry type comprehensive machining center



龙门铣床 gantry type milling machine



喷砂房 sandblasting room



伸缩式喷漆房 retractable paint booth



组装车间 assembly workshop



开料 cutting
↓
加工 machining
↓
表面处理 surface treatment
↓
总装 assembly

模具及精密零部件加工
Fabrication of dies and spare parts



立式加工中心 vertical machining center



高速加工中心 high-speed machining center



数控车床 CNC lathe



线切割机床 wire EDM machine



三座标仪 coordinate measuring machine



激光投影仪 laser projector



精密模具 precision dies



模具安装 dies assembly

加工 machining
↓
检测 inspection
↓
装配 assembly

客户分布 Customers Distribution



旗下企业 (holding company)

★ 中山市奥默生精密机械有限公司
从事精密模具及零件的加工制造

★ 中山市奥翔机械有限公司
从事各类机械零件的加工

★ 柳州智造工业有限公司
从事大型机械制造、液压设备、环保设备

国外代理商 (foreign agency)

★ 欧洲 (土耳其) Europe (Turkey)
Evk Industries co.-Istanbul
T: +90-212-5014443
Jaden (H.K) Development Ltd

★ 非洲 (阿尔及利亚) Africa (Algeria)
广州电器科学研究所 (广州擎天实业有限公司)
Guangzhou Kinte Industrial Co.,Ltd.
T: 020-86985888 F: 020-86985777

★ 北美 (North America) Market
HVAC MACHINE
www.hvacmachine.net
T: 260-760-7379

★ 泰国 (Thailand) Market
铭诚自动化机械有限公司
Ming Chen Auto Machinery Co.,Ltd.
T: 02-7084355

CONTENT 产品目录

▶ Tube processing equipments 配管加工设备 P 7-13

- ★ CNC tube bender 数控弯管机 P 7
- ★ CNC tube integrated machine (cut ,end form ,bend) 数控开料管端弯管组合机 P 9
- ★ CNC tube chipless cutting machine 数控无屑开料机 P 10
- ★ Tube end forming machine 管端加工机 P 11
- ★ CNC flute type punching machine 冲孔机 P 12
- ★ CNC closing machine with spinning mode 封口机 P 13
- ★ CNC spinning machine 数控旋压机 P 13

▶ Heat exchanger processing equipments 空调换热器加工设备 P 14-23

- ★ Hairpin bender 长U弯管机 P 14
- ★ Return bender 小弯头成型机 P 15
- ★ Ring inserted machine 套环机 P 16
- ★ Washing machine of small U 小U清洗机 P 16
- ★ Heat-exchanger (coil) forming machine 换热器成型设备 P 17
CNC coil bender of (L. O. U. G) shape 数控 (L. O. U. G) 型折弯机
Evaporator cut and bend machine 蒸发器切割折弯机、Evaporator cut machine 蒸发器切割机
- ★ Tube expander 胀管机 P 19
- ★ Fin press 高速翅片生产线 P 24

▶ Tooling and Consumable parts 各种模具及耗材 P 25

▶ Decoiler of various kinds 各种放料架 P 27

▶ Sheet metal processing machine 钣金加工设备 P 28

- ★ Sheet metal bending machine 钣金折弯设备 P 28
- ★ Sheet metal spinning machine 钣金旋压设备 P 28

▶ Refrigerator condenser processing equipment 冰箱冷凝器加工专用设备 P 29

▶ Other auto mation equipment 其它自动化设备 P 31

▶ Environmental equipment 环保设备--固体废弃物破碎系统 P 33



奥美森南区工业园
OMS industrial park

数控弯管机 CNC tube bender

TBM25-R2



● 选型 option

TBM TBCM TBCEM

TBM: 数控弯管机
CNC tube bender
TBCM: 数控开料弯管机
CNC tube cutting and bending machine
TBCEM: 数控开料弯管一体机
CNC integrated machine (cut, end form, bend)
TBCM: 机头转动开料弯管一体机
Machine head rotating integrated machine

最大弯管管径(铜):
max process tube dia.
(copper)
10: φ10mm
20: φ20mm
25: φ25mm
30: φ30mm
40: φ40mm
50: φ50mm
65: φ65mm
80: φ80mm
110: φ110mm

R: 右弯
right bending
L: 左弯
left bending
RL: 左右复合弯
right bending and
left bending

1: 单模
single die
2: 双模
double dies
n: 多模
multi-dies

无: 标准型
null: normal
H: 系统定制型
system customized
Q: 快速换模
quick die change
A: 自动上下料
auto loading and
unloading
J: 经济型
economic type



TBM50-R1H



TBM20-R1A



TBM20-R2



TBM20-R3



标准CNC系统
standard CNC system



高性能CNC系统
high - performance CNC system



夹爪 jaw
芯头 mandrel
圆模 bending die
夹模 clamping die
随动模 following die

特殊弯管机 Special tube bender

TBCM10-RL2

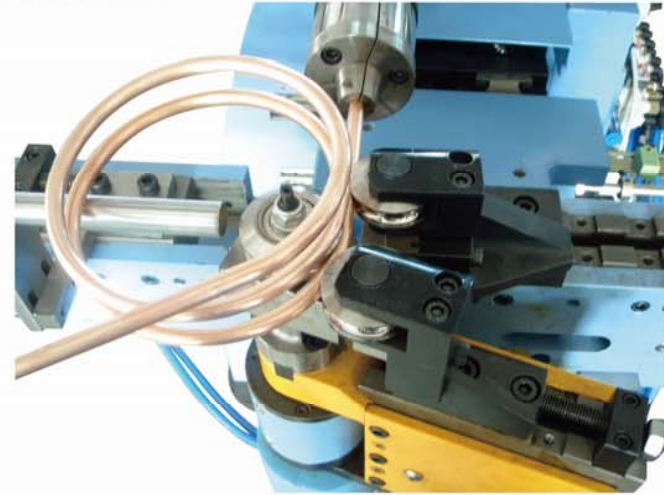

热水器盘管
coil pipe in water heater



数控开料弯管一体机
(每次只能弯一根管)
Tube cutting and bending
integrated machine (only one
tube processed at one time)

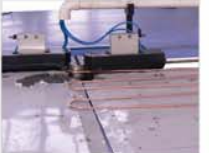

★ 可根据客户的要求, 定制各种管材、线材、型材弯制的专用设备。

The machine is applied to bend various tubes and wires and bars, which can be customized according to your demand.

平面(蛇型弯管机)

Snake shape bending machine

TBM10-RL1



一次弯8-12根管
8-12 tubes processed at one time

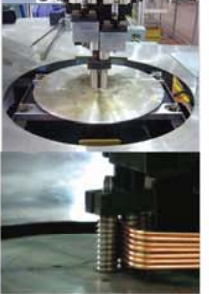

★ 主要应用于: 冰箱、冷柜、发热管的弯制

Function: The machine is used to bend tubes for refrigeratory, freezers and heaters tube

数控开料管端弯管组合机 CNC tube combined machine (cut ,end form,bend)

数控开料管端弯管一体机

CNC tube integrated machine (cut, end form, bend)

TBCEM15-R1



机头转动开料管端弯管一体机

machine head rotating integrated machine

TBCMM15-R1



★用途：空调配管三维成型的全自动设备，可实现将盘型铜管校直、定尺、无屑切断、管口成型、三维弯管。
Function: This fully automatic machine performs tube straightening, cutting, end forming and bending.

数控开料管端成型机 CNC tube cutting and end forming machine

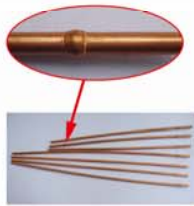

平放被动式放料架
passive horizontal decoiler



TCEM5-2/XP

TCEM20-4/1200Q4



内抽式放料架
eye-to-sky decoiler



数控无屑开料机 CNC tube chipless cutting machine

TCM20-2+2/1200E



● 选型
option

TCM TCEM

TCM:
数控无屑开料机
CNC tube cutting machine
TCEM:
数控开料管端成型机
CNC tube cutting and end
forming machine

最大加工管径:
max process
tube dia.
13: φ 13mm
20: φ 20mm
25: φ 25mm
40: φ 40mm

1: 单管 single tube
2: 两管 two tubes
4: 四管 four tubes
2+2: 双两管
double two tubes

一次送料长度:
once feeding length
300: 300mm
1200: 1200mm
X: 连续送料
continuous feeding

放料架方式:
decoiler type
E: 电动式
motorized decoiler
Q: 内抽式
eye-to-sky decoiler
P: 平放被动式
passive decoiler

放料架可旋转:
rotating type decoiler
无: 单面
null: one side rotating
2: 双面
two sides
2R: 双面旋转(一面使用另一面备料)
two sides rotating
(one side for use, the other side
for preparation)

TCM5-2+2/XE

★特点：皮带连续送料，效率高，多用于3m 以上管材的下料

Features: continuous feeding by belts, high efficiency, cutting long tube (≥3m)



打断机构，适用于短管下料
snapping mechanism for short
tube cutting



刀头旋转，无屑切割
cutter-rotating ,chipless cut



校直机构
straightener



★ 防护网或光幕为选配件

Optional: Safety fence or light curtain

管端加工机 Tube end forming machine

TE1K30-6/F



TE1K20-3/F



● 选型 option

TE

TE: 管端加工机
Tube end forming machine

加工面: process side
1: 单头 single end
2: 双头 two ends

类别: type
M: 数控旋压机 CNC spinning machine
K: 扩缩口 expansion and swaging
H: 混合型 mixed

最大加工管径: max process tube dia.
20: ϕ 20mm
30: ϕ 30mm
40: ϕ 40mm
60: ϕ 60mm
100: ϕ 100mm

工位模数: number of position
1: 单工位 one position
3: 三工位 three position
n: 多工位 multi-position

加工方式: process mode
F: 直冲式 flinging mode
C: 旋压式 spinning mode
L: 车削 lathe

无: 标准型 null : normal
A: 自动上下料 auto loading and unloading
B-Z: 其它定制型 customized

TE1K100-3/F



TE1K40-1C



冲孔机 CNC flute type punching machine

TDM80-2000B2

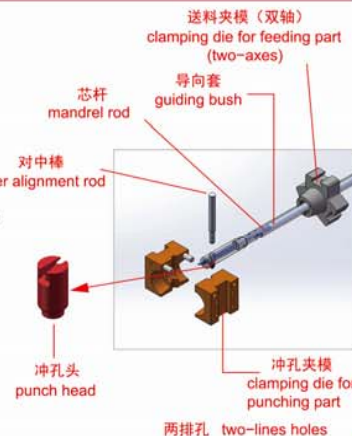

★ 最小加工管径: ϕ 12mm
Min process pipe dia.: ϕ 12mm

● 选型 option

TDM

TDM: 冲孔机
CNC flute type punching machine

最大加工管径: max process tube dia.
20: ϕ 20mm
50: ϕ 50mm
80: ϕ 80mm
110: ϕ 110mm

最大加工长度: max process tube length
1500: 1500mm
2000: 2000mm
L: 长度定制型 Length customized

控制轴: control axis
B1: 单轴 one axis
B2: 双轴 two axes



拨孔机

Tube hole drilling machine

TDA50



拨孔头 T-drill



拨孔工件 drilling product





数控旋压封口机 CNC closing machine with spinning mode

TE1F80-1/C

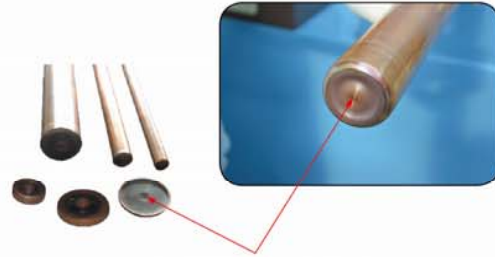

中心点需进行点焊, 才能完全密封
Spot welding in the middle part to seal up tube completely

● 选型 option

TE1F

TE1F: 数控旋压封口机 CNC closing machine with spinning mode

1/C

最大加工管径: max process tube dia.
30: ϕ 30mm
50: ϕ 50mm
80: ϕ 80mm
110: ϕ 110mm

数控旋压机 CNC spinning machine

TE1M50-A2

● 选型 option

TE

TEM: 数控旋压机 CNC spinning machine

M

加工面: process side
1: one end
2: two ends

A

最大加工管径: max process tube dia.
30: ϕ 30mm
50: ϕ 50mm
60: ϕ 60mm
80: ϕ 80mm
无: 标准型 (手动上下料) null: normal
A: 自动上下料 auto tube -loading /unloading
A2: 自动上下料且可调头 auto tube-loading/unloading and ends-changeover



长U弯管机 Hairpin bender

TBLU7-8/1300-M2Q



自动传输接料架
automatic conveying tube-collector

★ 特点(features):

伺服定尺退料, 伺服电机机架平移, 伺服折弯
cut-length setting, frame moving, tube bending and stripping are controlled by servo motor
送料由变频电机驱动, 皮带送料
belt feeding, driven by variable frequency motor
刀头电机由变频器驱动, 高低速可调
cutter motor is driven by transducer, and the speed can be adjusted



● 选型 option

TBLU

TBLU: 长U弯管机 Hairpin bender

加工管径(mm): max process tube dia.
5: ϕ 5mm
7: ϕ 7mm
.....
15.88: ϕ 15.88mm

加工管数: number of tube process at one time
4: 4管 (tubes)
6: 6管 (tubes)
7: 7管 (tubes)
8: 8管 (tubes)
6+6: 12管 (tubes)

最大加工长度: max process tube length
1300mm 3800mm
1700mm 4300mm
2200mm 5000mm
2700mm 6000mm
3200mm

中心距个数: number of centres
M1: 单模型 single die
M2: 双模型 double dies

放料架方式: decoller type
E: 电动式 motorized decoller
Q: 内抽式 eye-to-sky decoller

卸料输送方式: unloading mode
无: 气动摇臂卸料 Null: pneumatic arm unloading
A: 皮带输送卸料 A: belt conveyor unloading

多中心距
multi-centres



双管径快速切换
quick change over between two tube diameters



两次送料同时折弯12根管
12 tubes can be bent at one time



铜管黑斑检测
copper black spot detection



★ 各特殊功能可定制 special function can be customized

小弯头成型机 Return bender

TBSU7-5/21Q



● 选型 option

TBSU / TBSC

TBSU:
小U弯管机
Return bender
TBSC:
多功能小弯头机
Multi-functional return bender

最大加工管径:
max process tube dia.
10: $\phi 10\text{mm}$
20: $\phi 20\text{mm}$
9.52: $\phi 9.52\text{mm}$(固定规格)

加工管数:
number of tube
process at one time
2: 2管 (tubes)
3: 3管 (tubes)
5: 5管 (tubes)

最大中心距
max pitch
无: 标准
null: standard
(管径 $\phi 10$时,中心距 <math><30</math>
(diameter<math><10</math>, pitch<math><30</math>)
(管径 $\phi 20$时,中心距 <math><50</math>
(diameter<math><20</math>, pitch<math><50</math>)
60: 定制 (中心距 >math>50</math>)
60: customization(pitch>math>50</math>)

放料架形式:
decoiler type
E: 电动式
motorized decoiler
Q: 内抽式
eye-to-sky decoiler
P: 被动式
passive decoiler

内抽式放料架 (适用于管径 $\phi 5\text{mm} \sim \phi 9.52\text{mm}$)
eye-to-sky decoiler (pipe dia: $\phi 5\text{mm} \sim \phi 9.52\text{mm}$)

电动式放料架 (适用于管径 $\phi 5\text{mm} \sim \phi 19.05\text{mm}$)
motorized decoiler (pipe dia: $\phi 5\text{mm} \sim \phi 19.05\text{mm}$)



小U套环机 Ring inserted machine

TH7-8M/21

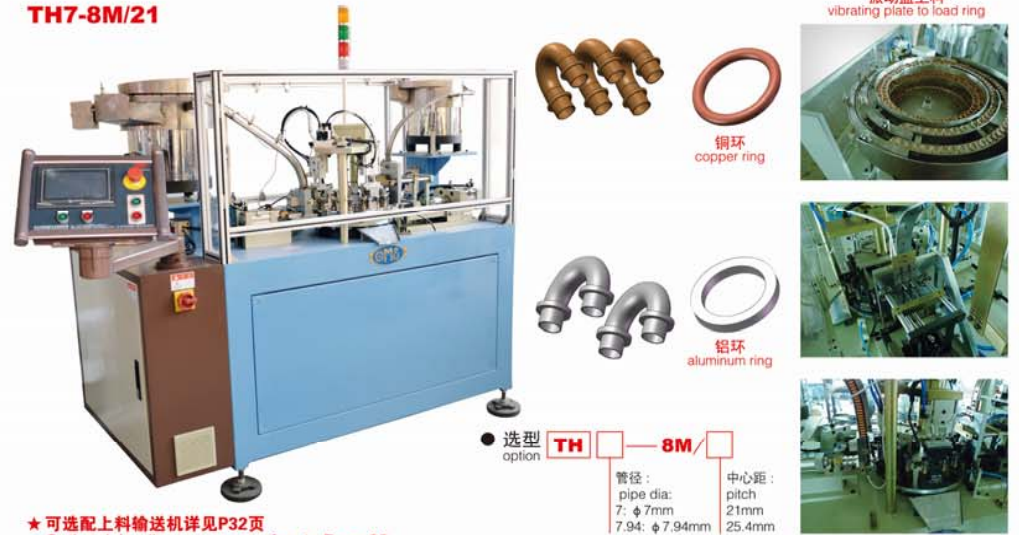

★ 可选配上料输送机详见P32页
Optional: loading conveyor refers to Page 32

全自动小U清洗机 Washing machine of small U

QXU9.52-3

★ 工作流程: 入料 → 清洗去毛刺 → 漂洗 → 烘干 → 出料
Work process: feed → deburr and clean → rinse → dry → discharge



★ 可选配上料输送机详见P32页
Optional: loading conveyor refers to Page 32

换热器成型设备 Heat-exchanger(coil)forming machine

L型冷凝器折弯机

L shape condenser bender

CDBM-1500/1F



折弯成型工件

Finished coils

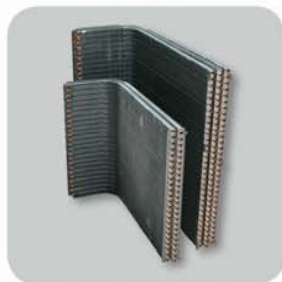

● 选型
option

CDB	EPB					
CDB: 冷凝器折弯机 Condenser bender	M: 伺服数控 servo control	工件最大宽度: max width of coil	弯位个数: number of bend	弯模横梁: beam type of bending die	无: 标准型 null: normal	
EPB: 蒸发器折弯机 Evaporator bender	E: 电动式 electric type	300: 300mm	1: 单弯L型或O型 single bend of L or O shape	C: 悬臂式 cantilever type	A: 自动上料 auto loading	
	A: 气动式 pneumatic type	850: 850mm	2: 双弯U型 double bend of U shape	F: 龙门框式 portal type	A2: 自动上下料 auto loading and unloading	
		1200: 1200mm	3: 三弯以上G型 multi-bend of G shape		B-Z: 定制型 customized	
		1500: 1500mm				
		1650: 1650mm				

★ 用途: 用于将空调室外机冷凝器折弯成一定角度, 呈“G”型或“U”型或“L”型, 以满足空调器整体设计及生产工艺。

Function: Used to bend air-condition condensers to a certain angle to make them into "G" shape or "U" shape or "L" shape, which satisfy the demand of air-condition overall design and producing technique.

G型冷凝器折弯机

G shape condenser bender

CDBM-1500/3C



折弯成型工件

Finished coils



换热器成型设备 Heat-exchanger(coil)forming machine

U型冷凝器折弯机

U shape condenser bender

CDBM-1200/2F-HL



★ 优点(Advantage):

三轴数控, 定位准确、折弯平稳
Three axes CNC control, accurate positioning, smooth bending
自动化程度高(调整方便, 自动上下料)
High degree automation(convenient adjustment, auto loading/unloading coil)
不易倒片
Fins are well protected, no collapse

折弯成型工件

Finished coils

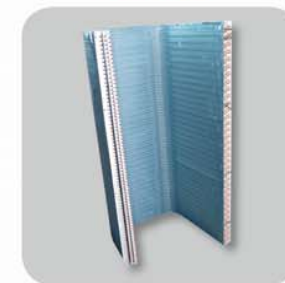

EPC / **EPCB**

EPC: 蒸发器切割机 Evaporator cutting machine	工件最大长度: max length of coil	切刀数: number of cut notch	弯位数: number of bend
EPCB: 蒸发器切割折弯机 Evaporator cut and bend machine	850: 850mm	1: 1刀 one cut notch	1: 1弯 one bend
EPCM: 数控蒸发器切割机 CNC evaporator cutting machine	1200: 1200mm	2: 2刀 two cut notch	2: 2弯 two bend

O型蒸发器折弯机

O shape evaporator bender

EPBM-300/1C



蒸发器切割机

Evaporator cutting machine

EPC-850/2C



蒸发器切割折弯机

Evaporator cut and bend machine

EPCB-1000/2-2

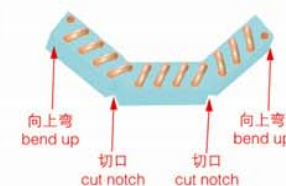

胀管机 Tube expander

立式胀管机
Vertical expander

CME7-53*4/1600L1



手动门方式上料
with manual door to load coil



自动翻转门方式上料
with turnover-door to load coil



CME9.52-46*6/2500L1F



选型
option

CME	CMEQ								
CME: 胀管机 Tube expander	CMEQ: 强制式胀管机 shrinkless expander with clamping fixture	加工管径: tube dia. 7mm 9.52mm 15.88mm	排列方式 (孔数x排数): pattern type (holes x lines)	最大加工高度: max process coil height 1200mm 1800mm 1300mm 2200mm 1500mm 2500mm 1600mm 2700mm	出力方向: strength direction L: 立式 vertical type W: 卧式 horizontal type	加工面: process side 1: 单面 single side 2: 双面 double sides A: 组合 combination	上料方式: coil-loading type 无: 标准型(手动门) null: normal (manual door) R: 旋转工作台(高度≤1600mm) rotary table (height≤1600mm) F: 自动翻转门 turnover-door		

高低排旋转双工位胀管机

Rotary double position expander for high - low row coil

CMED7-65*4/1200L2R



★特点(features):

高低排胀管不需要更换U托及胀杆, 只需程序中设定参数就可自动调节
high - low row expanding does not need to change U - receiver and expanding rods, automatic adjustment can be realized by setting program parameters

U托板及胀杆安装板分别由伺服驱动
U - receiver board and expanding rod installation board are controlled by separate servo motors

高低排U托
high-low row U-receiver

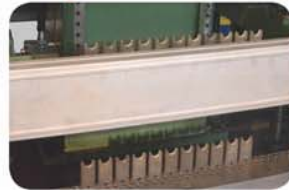

高低排工件
high-low row coil



胀管机 Tube expander

快速换模立式胀管机

Vertical expander(quick die changeover type)
CME7.94-40*10/2500L1FQGLBA



★特点(features):

自动调整不同工件的规格参数, 可存储记忆, 快速换型
parameters can be adjusted automatically for different coil types. Set-up data for each coil type can be memorized. Changeover between different coil types is very quick.

★主要功能(function):

- 自动选择胀杆(QG)
automatic expansion rod selection
- 自动控制工件高度(QL)
automatic control of coil height
- 快速调节前门板和后门板, 可自动储存, 快速更换(QB)
quick adjustment of front door panel and back door panel, automatic data memorization, quick changeover.
- 可配接自动上下料输送装置(QA)
optional conveyor for auto loading and unloading

自动选择胀杆
automatic selection of expansion rod



前门板(自动调控高度及位置)
front door panel (auto adjusting height and position)



后门板(自动调控高度及位置)
back door panel (auto adjusting height and position)



强制式胀管自动线

Automatic line of shrinkless expanding

CMEQ7-43*4/1200L4A

★工作流程: 人工上料(双上料工位)→自动胀管→自动二三次扩口→机械手卸料

work flow: loading by hand (two loading positions)→automatic expanding→automatic flaring and collaring→manipulator unloading

双上料工位
double loading position



胀管工位
expanding position

扫描扩口工位
scan flaring position

卸料机械手
manipulator for unloading

对接输送机
conveyor



平均效率 20秒/件
average efficiency 20 seconds / coil

人工上料间隔 40秒/两件
manual loading interval 40 seconds / 2 coils

强制式胀管机 Shrinkless expander with clamping fixture

CMEQ9.52-36*3/1200L2R



胀管主动力
expanding power

伺服调控产品高度
the coil process height
is adjusted by servo

扫描扩口 (杯口不易开裂, 工件不变形, 不折管)
scanning flaring
(No cracks at the flaring end, no deformation of coil, no bent tubes)

旋转工作台
rotatable table

双工位旋转台
two-position rotatable table



扫描扩口
scanning flaring

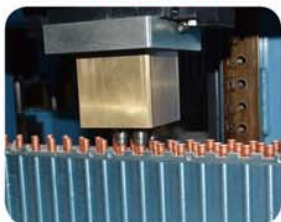

U型锁
U shape lock



上夹头
upper collet

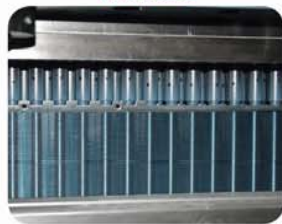

- ★ 优点: 可节约铜管2.5%~3%, 节省能源50%以上
advantage: The new type tube expander can save copper tube by 2.5%~3%, and energy up to 50%
- ★ 以 $\phi 7*21$ (排距) 为例, 该机型有四种最大孔数选择
For $\phi 7*21$ (OD*Row distance), there are 4 options for maximum processing holes
CMEQ7-32*3/1100L2R CMEQ7-54*3/1300L2R
CMEQ7-43*3/1200L2R CMEQ7-65*3/1300L2R

卧式组合胀管机 Horizontal combined expander

卧式组合胀管机

Horizontal combined expander

CME9.52-12*1/4000WA

主要适用于直管胀管, 一端夹持, 另一端自然收缩
It is mainly used in the expanding of straight tubes. One end of the coil is clamped, and the other end shrinks naturally



可加工椭圆管工件
Capable of processing oval tube coils



- ★ 优点: 数控编程、自动移动、1次胀1-n根管、多次组合, 适用于大型工件的胀管。
advantage: CNC program, automatic shift, 1-n tubes process at one time, multi-times combination, suitable for expanding big coil

选型
option

CME	CMEQ					
CME: 胀管机 Tube expander	CMEQ: 强制式胀管机 shrinkless expander with clamping fixture	加工管径: tube dia. 7mm 9.52mm 15.88mm	排列方式 (孔数x排数): pattern type (holes x lines)	最大加工高度: max process coil height 2200mm 2700mm 3200mm 4000mm 5000mm 6000mm	出力方向: strength direction W: 卧式 horizontal type	加工面: process side 1: 单面 single side 2: 双面 double sides A: 组合 combination 上料方式: coil-loading type 无: 标准型(手动门) null: normal (manual door) R: 旋转工作台(高度 ≤ 1600mm) rotatable-table (height ≤ 1600mm) F: 自动翻转门 turnover-door

强制式卧式组合胀管机

Shrinkless horizontal combined expander

CMEQ9.52-10*1/3000WA



弹性夹头
elasticity collet



工件中U管为无规律排列时采用整体U托板

A holistic receiver board is recommended when the array of hairpin inside the coil is irregular

★ 可按客户要求定制

We can make the machine according to your request

卧式胀管机 Horizontal expander

CME7-64*5/3200W1F



★ 优点: 一个工作循环内完成胀管、扩口及翻边的工艺过程。
advantage: expanding, flaring, and collaring are finished in one cycle



卧式自动上下线强制胀管机
Auto loading and unloading shrinkless horizontal expander

CMEQ7.94-64*8/5000W1QA

★ 工作流程: 人工穿管→穿管平台移位→自动输送到胀管工位→自动胀管扫描扩口→自动输送升降→出料到下料平台→自动输送到折弯机
work flow: Inserting hairpin tubes into fins by hand→trimming the coil on the platform→coil transmitted to expanding position by auto conveyor→automatic expanding→scan flaring→auto conveyor rising and falling→processed coil transmitted to unloading platform→transmitted to coil bender by auto conveyor

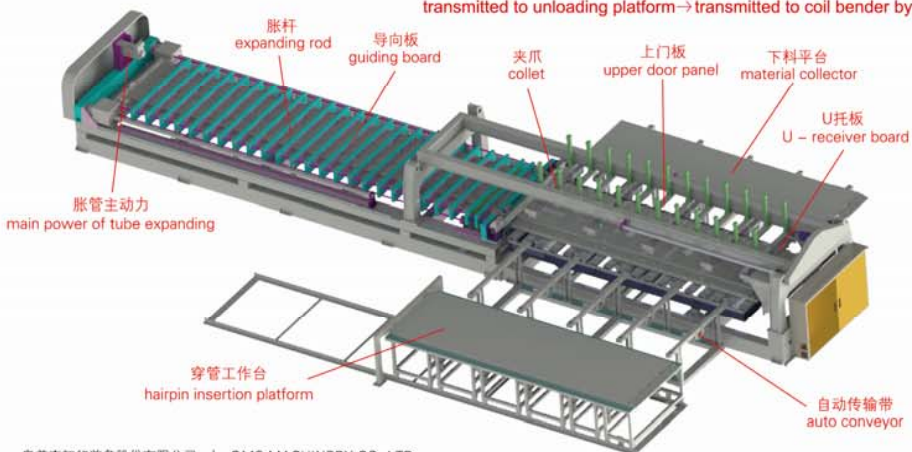

高速翅片生产线 Fin press

HFL1250KN-2R

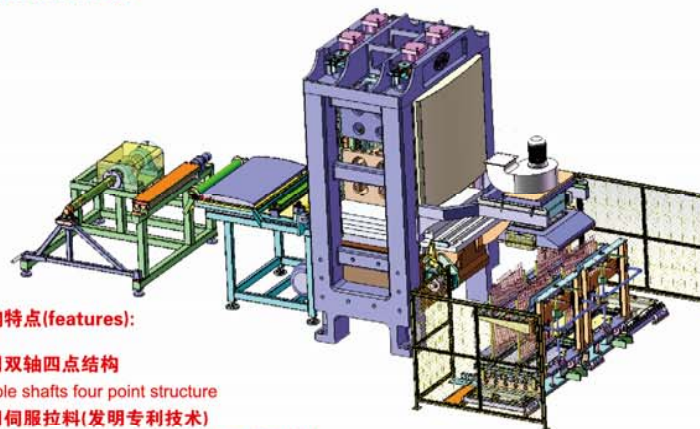

★ 结构特点(features):

采用双轴四点结构
double shafts four point structure
采用伺服拉料(发明专利技术)
servo motor pulling material (patented design)

● 选型
option

HFL

KN

R

加工能力:
capacity
630: 63吨 (ton)
1250: 125吨 (ton)

接料方式:
fins stacker type
1: 接料小车(stacker trolley)
2: 2工位(two-position)
3: 三工位(three-position)

R: 旋转接料 (rotating stacker)
P: 平移接料 (shifting stacker)
C: 小车接料 (cart stacker)

接料小车
cart stacker

HFL630KN-2R

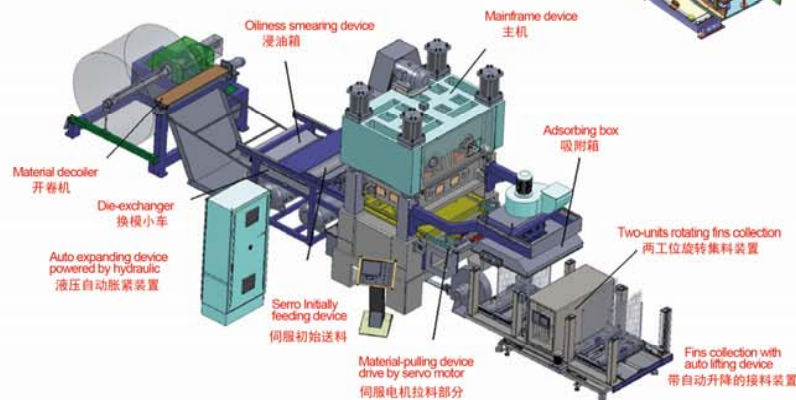



胀管机 Tube expander machine

1. 接受器 (U托) U - shape receiver	5. 弹性夹爪 collet	9. U托板 U-receiver board
2. 扩口器 flaring device	6. 夹爪套 collet bush	10. 夹爪套安装板 collet bush installation board
3. 胀球 expansion bullet	7. 夹爪加长杆 collet bush extension rod	11. 胀杆锁紧板 expansion rod locking board
4. 胀球螺钉 expansion bullet screw	8. 胀杆 expansion rod	



数控开料机 CNC tube cutting machine

1. 夹模 clamping die
2. 切刀座 (刀盘) cutter base
3. 外切刀 exterior cutting blade
4. 托刀及托轮轴承 bearing
5. 定芯接头 joint
6. 推轮 pushing wheel
7. 校直轮 straightening roller
8. 校圆轮 rounding roller
9. 导套 guide bush
10. 垫套 washer bush
11. 进料导向套 feeding guide bush



小弯头成型机 Return bender machine

1. 送料夹模 feeding clamping die
2. 靠模 following die
3. 芯轴 mandrel
4. 夹紧模块 clamping mould
5. 弯曲模 bending die
6. 芯轴支架 mandrel bracket
7. 锯片 saw blade
8. 退料针 stripping needle
9. 导料管 material guide bush



长U弯管机 Hairpin bender machine

1. 切刀座 (刀盘) cutter base	7. 校圆轮 rounding roller	13. 芯杆固定杆 mandrel rod fixing pole
2. 外切刀 exterior cutting blade	8. 抱紧光轴 holding shaft	14. 进料导向套1 feeding guide bush 1
3. 接头 joint	9. 弯曲模 bending die	15. 进料导向套2 feeding guide bush 2
4. 轴承 bearing	10. 夹模 clamping die	16. 退料套 stripping bush
5. 芯轴 mandrel	11. 靠模 pressure die	17. 切割同步带 cutting synchronous belt
6. 校直轮 straightening roller	12. 吹气接头 air blow joint	18. 送料皮带 feeding belt



弯管机 CNC tube bender

1. 圆模 bending die	5. 夹爪 collet
2. 夹模 clamping die	6. 同步带 synchronous belt
3. 靠模 pressure die	7. 链条 chain
4. 芯棒头 mandrel	

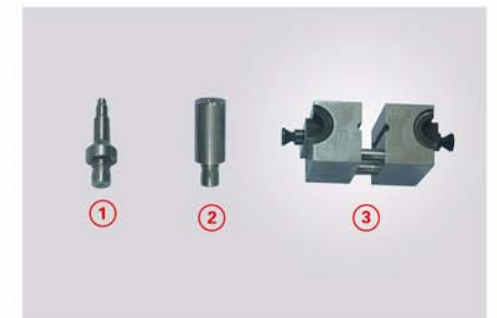

管端加工机 Tube end forming machine

1. 冲头 flaring punch
2. 缩口模 reducing die
3. 夹模 clamping die

各种放料架 Decoiler of various kinds

适用于采用卷料的全自动设备 (Suitable for fully automatic equipment using coil tubes)



Q. 正抽式放料架
Q. front pulling eye-to-sky decoiler
(有导向轮导向, 阻力小适用于管径 $\phi 5\text{mm} \sim \phi 9.52\text{mm}$ 的薄壁管)
(equipped with guiding pulley, low resistance, suitable for tube diameter $\phi 5\text{mm} \sim \phi 9.52\text{mm}$, with thin wall thickness)



QF. 反抽式放料架 (节省位置)
QF. reverse pulling eye-to-sky decoiler(space saving)
(适用于壁厚 0.4mm 以上, 管径 $\phi 5\text{mm} \sim \phi 9.52\text{mm}$ 的厚壁管)
(suitable for tube diameter $\phi 5\text{mm} \sim \phi 9.52\text{mm}$, with thin wall thickness over 0.4mm)



PE. 平放电动式放料架
PE. motorized horizontal decoiler
(适用于管径 $\phi 4.76\text{mm} \sim \phi 19.05\text{mm}$ 无木盘卷料)
(suitable for tube coils with no wooden reel Tube diameter 4.76mm to 19.05mm)



P. 平放被动式放料架
P. passive horizontal decoiler
(适用于管径 $\phi 4.76\text{mm}$ 以下无木盘卷料)
(suitable for tube coils with no wooden reel Tube diameter $< \phi 4.76\text{mm}$)



E. 电动式单面放料架
E. Single-side motorized decoiler
(适用于管径 $\phi 4.76\text{mm} \sim \phi 19.05\text{mm}$)
(pipe dia: $\phi 4.76 \sim \phi 19.05\text{mm}$)



E2. 电动式双面放料架 (节省位置)
E2. Double-side motorized decoiler (space saving)
(适用于管径 $\phi 4.76\text{mm} \sim \phi 19.05\text{mm}$)
(pipe dia: $\phi 4.76 \sim \phi 19.05\text{mm}$)



ES. 电动胀紧式单面放料架
ES. Single-side motorized decoiler (expansion type)
(适用于无木盘的卷料, 常用于汽车铝管的开料)
(suitable for coils with no wooden reel, it is often used for cutting aluminum tubes in the automotive industry)



ER. 电动式双面旋转放料架
ER. Rotatable double-side motorized decoiler
(适用于管径 $\phi 4.76\text{mm} \sim \phi 19.05\text{mm}$)
(pipe dia: $\phi 4.76 \sim \phi 19.05\text{mm}$)



钣金加工设备 Sheet metal processing equipments



奥美森智能装备

钣金折弯机 Sheet metal bending machine

★ 用途: 冰箱、冷柜及豪华空调的钣金折弯, 实现整体加工。
Function: the machine is used to bend sheet metal for refrigeratory and air conditioner.



折弯成型产品 finished product

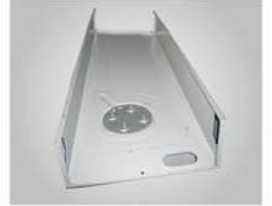

进料可配置输送带
equipped with convey belts for loading and unloading



★ 优点: 喷塑后再折弯, 也不会损坏表面, 可提高效率, 减少周转。
Advantage: even though sheet metal has been sprayed by plastics, there is no surface damage during bending, which can increase efficiency and reduce turnover

钣金旋压机 Sheet metal spinning machine (Edge bending machine)

★ 用途: 用于空调末端工程的加工。
Function: the machine is used to process sheet metal with spinning mode, which is applied to air-conditioner terminal procedure.



折弯成型产品 finished product

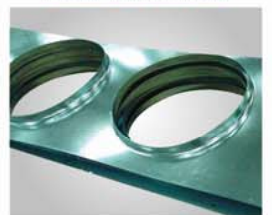

成型模具 forming die



★ 特点(features):
模具更换方便
easy to change die
旋压翻边高度可调
collar height is adjustable
可弹性生产, 灵活度高
flexible production

蛇型弯管机

Serpentine bending machine

★用途：将盘管校直、定尺、无屑切断后，自动集料 4 ~ 16根，然后自动送到弯曲机，实现全自动开料弯管全过程

Use: The machine straightens the coiled tube, set to length and chipless cut the tube. After 4 to 16 tubes are cut and collected, the tubes are automatically transmitted to the bending part of the machine. It realizes the fully automatic process of cutting and bending

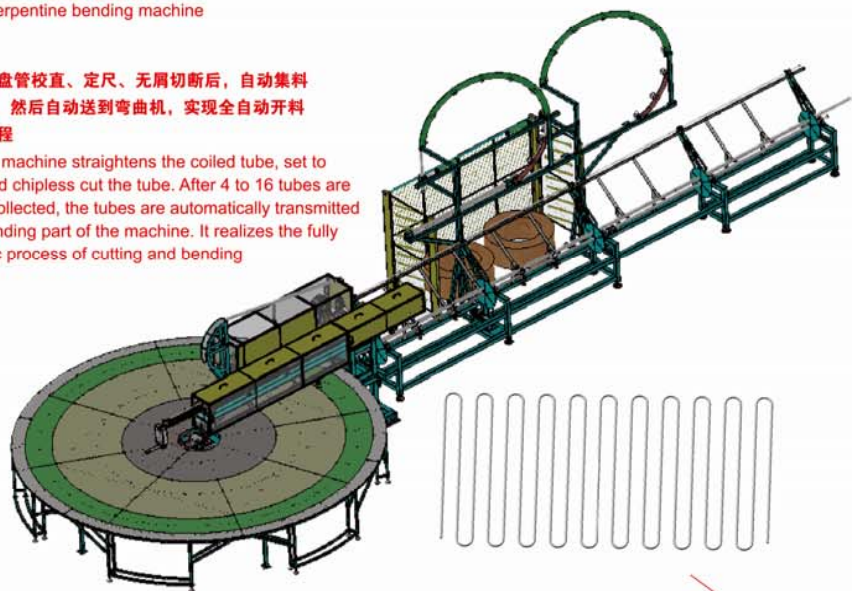

冷凝管翻转机

Condenser tube turn-over machine

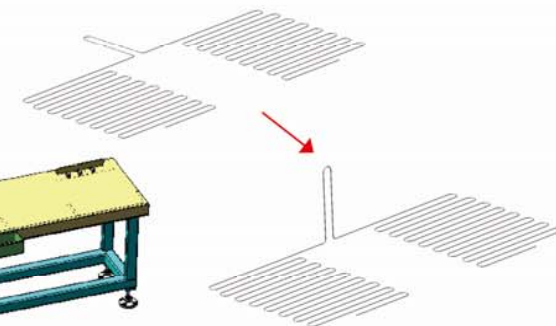
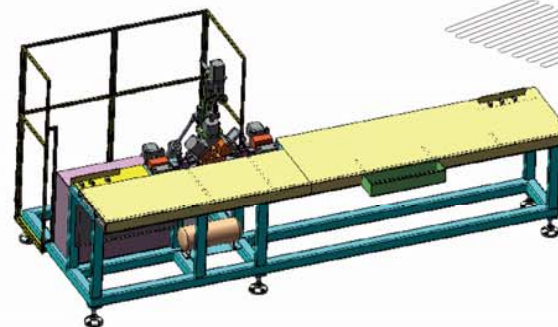

高速翅片生产线

Fin press

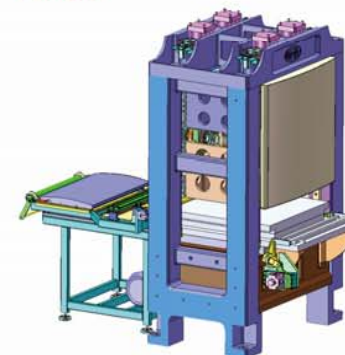

冷凝管扭转机

Condenser tube twisting machine

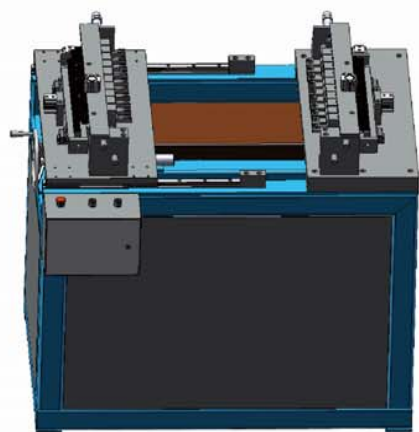

冰箱冷凝器
Refrigerator condenser

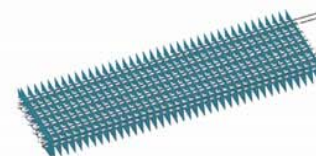
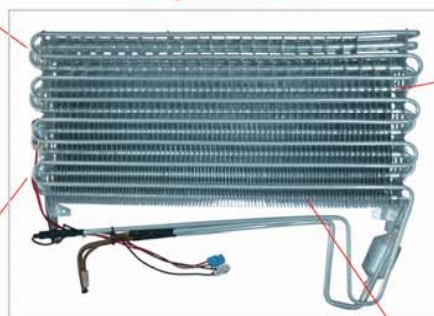

冷凝管折叠机
Condenser folding machine

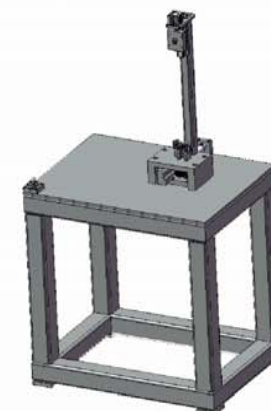

管材成型自动生产线 Automatic tube forming line

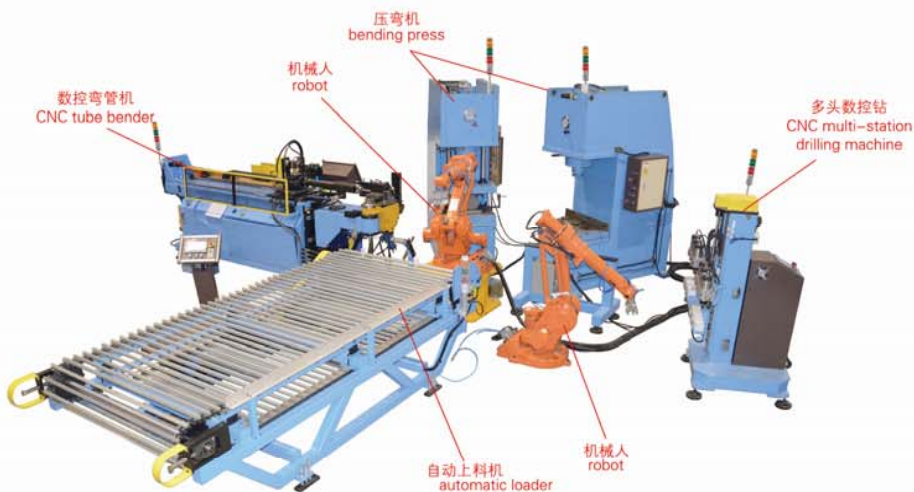

★ 可根据客户的要求，定制各类管材弯制成型的专用设备。
We provide customized tube bending and forming equipment according to customer's specific requirements.

集流管生产设备 Micro - channel production

扁管孔冲压机
Oblate tube hole punching machine

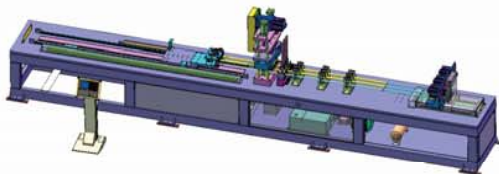

扁管开料机
Micro - channel tube cutting machine



集流管自动装配机
Micro - channel tube assembly machine



微通道热交换器
Micro - channel heat exchanger



自动焊接机 Automatic welding machine



焊接机器人 welding robot



焊接工件 welding product

★ 可按客户要求订制各类自动焊接机
We produce various welding machines according to customer's requirements

自动上下料机 Automatic loading and unloading

管端加工自动上下料机
Auto loading and unloading unit for end forming machine



(本机适用于管端加工机)
(suitable for End forming machine)

弯管自动上下料机
Auto loading and unloading unit for CNC tube bender



(本机适用于数控弯管机)
(suitable for CNC tube bender)

上料输送机
Loading conveyor

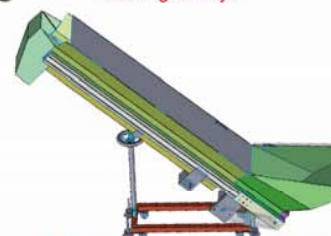

(本机适用于套环机、全自动清洗机)
(Suitable for ring inserted machine, and U bend washing)

垃圾破碎机 Waste shredding machine



D系列 双轴破碎机
D series double shaft shredder

- ★ **低转速，高扭矩**
Low rotating speed, large torque
- ★ **动刀采用特殊钢制造，耐磨、使用寿命更长**
Cutter made of special steel, wear-resisting, long working life
- ★ **剪切式破碎、防缠绕**
Shearing type shredding, anti winding
- ★ **机架坚固、抗高扭矩**
Firm machine frame, resistant to large torque
- ★ **运行及维护成本低**
Low operating cost and low maintenance
- ★ **自动反转**
Automatic reversal



E系列 重型垃圾粗破碎机
E series Rough shredding machine



L系列 单轴破碎机
L series Single shaft shredder



台湾某纸业集团破碎机生产线现场 Shredding site of the paper company in Taiwan



上海青浦区某RDF生产线现场 RDF production site in Shanghai



★ 详细资料请索取奥美森恒动环保事业部的产品画册
For detailed information, please refer to the product catalogue of Hengdong environmental business department.